

FRAME RAILS & COMPONENTS

S&W frame rails are designed for the do-it-yourselfer wishing to narrow his or her rear frame section to accommodate modern drag race or pro/street tires. Made from 2"x3"x.083" wall mild steel rectangular tubing, and mandrel formed on our own computer controlled machinery, they are substantially lighter than stock rear frames. These frame rails offer the do-it-yourselfer the added savings of less expensive U.P.S. shipping charges. All S&W frame rails are sold in pairs.

Direct Fit Rear Frame Rails

S&W direct fit rear frame rails are designed for applications where retaining the rear floor pan is either more practical or more desirable. These rails are designed to follow the original rear floor contour and install with minimal cutting or modifications. These rails are available to either retain the original rear leaf springs (if so equipped) or in coil-over versions for the builder wishing to update his rear suspension with the addition of coil over shocks or an S&W Pro/Series 2000 shock & spring kit. Sold in pairs. S&W frame connectors are designed to be used in conjunction with our rear frame rails. They provide additional stiffness to your stock bodied car by tying the front subframe to the rear frame rail.

Rail	Connector	Description
10-001	10-601	67-69 Camaro, Firebird • leaf spring
10-003	10-601	67-69 Camaro, Firebird • coil-over
10-004	10-604	70-81 Camaro, Firebird • leaf spring
10-104	10-604	70-81 Camaro, Firebird • coil-over
10-005*	included	82-92 Camaro, Firebird • coil-over
10-028**	included	82-92 Camaro • 4-link SS/GT
10-006*	included	64-72 Chevelle, GTO, 442 • coil-over
10-007	40-213-3	55-57 Chevy • coil-over
10-008	10-608	62-67 Chevy II • leaf spring
10-009	10-608	62-67 Chevy II • coil-over
10-010	10-610	68-78 Nova, Ventura • coil-over
10-012	10-610	68-78 Nova, Ventura • leaf spring
10-011*	included	63-81 Corvette • 4-link, coil-over
10-013	10-613***	Vega, Monza • coil-over
10-014*	included	78-88 GM Intermediate • coil-over
10-031	10-631	Mopar A Body • coil-over (except 67-69 Barracuda)
10-032	10-632	Mopar A Body • leaf spring (except 67-69 Barracuda)
10-033	10-633	Mopar E Body • leaf spring
10-035	10-633	Mopar E Body • coil-over
10-036	10-636	Mopar B Body • coil-over
10-039	10-639	Arrow • coil-over
10-040	10-631	67-69 Barracuda • coil-over
10-041	10-632	67-69 Barracuda • leaf spring
10-089	10-689	94 Mustang GT
10-090	N/A	48-53 Anglia
10-091*	included	1940 Ford • coil-over
10-092	10-692	64-73 Mustang, 70-77 Maverick • coil-over
10-093	10-693	64-73 Mustang, 70-77 Maverick • leaf spring
10-094	10-694	61-65 Falcon • coil-over
10-095	10-695	Pinto, 74-93 Mustang • leaf spring
10-096	10-696	Pinto, 74-93 Mustang • coil-over
10-097	10-697	68-70 AMX • coil-over
10-099	10-699	66-67 Fairlane • coil-over
10-100	10-699	66-67 Fairlane • leaf spring

Coil Over Frame Rails **\$189⁹⁵**

Leaf Spring Frame Rails **\$199⁹⁵**

Connectors..... **\$39⁹⁵**

* These frame rails **\$249⁹⁵**

** These frame rails **\$299⁹⁵**

*** These connectors **\$63⁰⁰**

Universal Rear Frame Rails

S&W universal 2" x 3" rear frame rails are designed for applications where removing the rear floor pan is either more practical or more desirable. These rails allow the builder to place the rail higher in the body resulting in a lower finished ride height. *Sold in pairs*

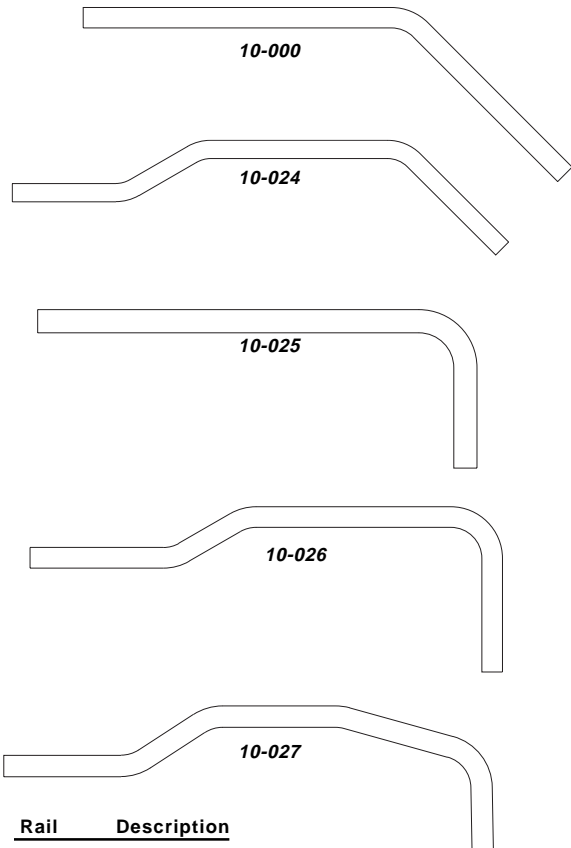

Rail	Description
10-000	Universal. 45 degree
10-024	Universal, ladder bar rail used in frame # 10-300
10-025	Universal, 90 degree
10-026	Universal, 90 degree with 6" drop
10-027	Universal 4-link rail as used in frame # 10-400

Universal Frame Rails **\$149⁹⁵ pair**

CUSTOM FRAME RAILS

S&W Race Cars can build you a custom pair of rails to your spec. Some restrictions do apply. Please call the S&W Sales Department for more info.

Item No.	Description	Price
10-030	Custom 2" x 3" x .083" frame rails	\$229⁰⁰
10-037	Custom 1-5/8" x .134" mild steel frame rails	\$229⁰⁰

BOLT ON FRAME CONNECTORS

S&W Race Cars, bolt on frame connectors are legal for all classes of drag racing and are highly recommended for all unibody cars where the stock rear subframe has not been replaced with 2" x 3" rectangular frame rails.

These bolt on connectors feature computer designed & produced brackets and are fixture assembled to assure proper final fit.



Item No.	Description	Price
10-601B	67-69 Camaro, Firebird	\$129⁹⁵
10-608B	62-67 Chevy II, Nova	\$127⁹⁹
10-695B	79-93 Mustang	\$129⁹⁹

